

Last Revised: 2014-11-06 07:14:43.0

High-Accuracy M Series Multifunction DAQ - 18-Bit, up to 625 kS/s, up to 32 Analog Inputs



- 16 or 32 analog inputs at 18 bits, 625 kS/s (500 kS/s scanning)
- Up to 4 analog outputs at 16 bits, 2.8 MS/s (3 μ s full-scale settling)
- 7 programmable input ranges (\pm 100 mV to \pm 10 V) per channel
- Programmable, onboard lowpass filtering
- Up to 48 TTL/CMOS digital I/O lines (up to 32 hardware-timed at 10 MHz)
- Two 32-bit, 80 MHz counter/timers
- Analog and digital triggering
- NI-MCal calibration technology for improved measurement accuracy

Overview

NI M Series high-accuracy multifunction data acquisition (DAQ) devices are optimized for 18-bit analog input accuracy. This resolution is equivalent to 5½ digits for DC measurements. To ensure accuracy, the NI-PGIA 2 amplifier technology is optimized for low noise and fast settling to 18 bits, and the onboard lowpass filter rejects high-frequency noise and prevents aliasing. M Series devices are ideal for applications including test, control, and design. All high-accuracy devices have a minimum of 16 analog inputs, 24 digital I/O lines, seven programmable input ranges, analog and digital triggering, and two counter/timers. They also have an extended two-year calibration interval.

[Back to Top](#)

Requirements and Compatibility

OS Information

- Linux®
- Mac OS X
- Windows 2000/XP
- Windows 7
- Windows Vista x64/x86

Driver Information

- NI-DAQmx
- NI-DAQmx Base

Software Compatibility

- ANSI C
- LabVIEW
- LabWindows/CVI
- Measurement Studio Professional Edition
- Visual Basic
- Visual Studio .NET

[Back to Top](#)

Comparison Tables

Family	Bus	Analog Inputs	AI Resolution (Bits)	Analog Outputs	AO Resolution (Bits)	Max AO Update Rate (MS/s)	AO Range	Digital I/O	Correlated (clocked) DIO
NI 6280	PCI, PXI	16	18	-	-	-	-	24	8, up to 10 MHz
NI 6281	PCI, PXI	16	18	2	16	2.8	Programmable per channel	24	8, up to 10 MHz
NI 6284	PCI, PXI	32	18	-	-	-	-	48	32, up to 10 MHz
NI 6289	PCI, PXI	32	18	4	16	2.8	Programmable per channel	48	32, up to 10 MHz

Application and Technology

M Series for Test

For test, you can use M Series high-accuracy analog inputs and 10 MHz digital lines with NI signal conditioning for applications including electronics test, component characterization, and sensor and signal measurements requiring instrument-class accuracy. The 18-bit analog-to-digital converter (ADC) and available filtering provide a 4 times increase in resolution and 5 times more measurement sensitivity. With fast sampling rates and a low noise floor, these devices can accurately acquire dynamic signals. For better noise rejection, the onboard lowpass filters significantly improve device accuracy. Advanced analog clamping circuitry protects the hardware from overvoltage conditions and ensures accurate measurements on nonsaturated channels. High-accuracy M Series devices are compatible with NI SCC and SCXI signal conditioning platforms, which provide amplification, filtering, and power for virtually every type of sensor. These platforms also are compliant with IEEE 1451.4 smart transducer electronic data sheet (TEDS) sensors, which offer digital storage for sensor data sheet information.

M Series for Control

M Series digital lines can drive 24 mA for relay and actuator control. By clocking the digital lines as fast as 10 MHz, you can use these lines for pulse-width modulation (PWM) to control valves, motors, fans, lamps, and pumps. With four waveform analog outputs, two 80 MHz counter/timers, and six DMA channels, M Series devices can execute multiple control loops simultaneously. The analog outputs on the high-accuracy M Series devices can generate up to 2.86 MS/s and provide user-defined programmable offsets and ranges for maximum waveform resolution over any custom range. High-accuracy M Series devices also have direct support for encoder measurements, protected digital lines, and digital debounce filters for control applications. With up to 32 analog inputs, 32 clocked digital lines, and four analog outputs, you can execute multiple control loops with a single device. For higher-count control loops, you can use M Series devices in conjunction and tightly synchronized with National Instruments analog output devices for 64 or more loops. With the NI SoftMotion Development Module for LabVIEW, you can create a complete custom motion controller with M Series devices.

M Series for Design

For design applications, you can use the wide range of I/O - from 32 analog inputs to 48 digital lines - to measure and verify prototype designs. M Series devices and NI LabVIEW SignalExpress interactive measurement software deliver benchtop measurements to the PC. With LabVIEW SignalExpress interactive configuration-based steps, you can quickly create design verification tests. The fast acquisition and generation rates of high-speed M Series devices along with LabVIEW SignalExpress provide on-the-fly design analysis. You can convert your tested and verified LabVIEW SignalExpress projects to LabVIEW applications for immediate M Series DAQ use and bridge the gap between test, control, and design applications.

Hybrid-Slot-Compatible PXI Modules

M Series modules for PXI are hybrid-slot-compatible so that you can use them in both PXI slots and the hybrid slots found in new PXI Express chassis. The PXI Systems Alliance specifies that hybrid-slot-compatible PXI modules use modified slot connectors to mechanically fit in both PXI slots and hybrid slots. This mechanical change:

- Provides compatibility with past, current, and future PXI chassis
- Maintains existing product specifications
- Requires no software changes (application or driver)
- Maintains speed and capability of all PXI communication (PXI Express signaling is not provided)

However, hybrid-slot-compatible PXI modules do not include the pins used to implement PXI local bus communication, which is used for backplane SCXI control from the right-most PXI slot in PXI/SCXI combination chassis (NI PXI-1010, PXI-1011, PXI-1050, and PXI-1052). For these applications, NI provides unmodified M Series PXI modules that maintain the required local bus capabilities. Refer to the SCXI Control of PXI/SCXI Combination Chassis section in the Ordering Information section for part numbers.

Simultaneous and Intelligent Data Acquisition

When you need to obtain performance from a data acquisition device beyond the capabilities of a multifunction DAQ device, National Instruments provides simultaneous sampling with the S Series and intelligent DAQ with the R Series. The S Series architecture dedicates an ADC per channel to provide higher aggregate sampling rates compared to multiplexed devices. S Series devices are ideal for applications including IF digitization, transient recording, ultrasound and sonar testing, and high-energy physics.

R Series multifunction DAQ devices contain a 1M/3M gate field-programmable gate array (FPGA) that is reconfigurable using the NI LabVIEW FPGA Module. These devices have up to eight independent 16-bit analog inputs with up to 200 kHz simultaneous sampling, up to eight independent 16-bit analog outputs with up to 1 MHz simultaneous update rates, and up to 96 digital I/O lines configurable at rates up to 40 MHz. You can customize these devices to develop capabilities such as complete control over the synchronization and timing of all signals and operations; user-defined onboard decision-making logic; and digital lines individually configurable as input, output, counter/timers, PWM, flexible encoder inputs, or user-defined communication protocols.

Signal Conditioning

Signal conditioning is required for sensor measurements or voltage inputs greater than 10 V. NI SCXI is a versatile, high-performance signal conditioning platform, optimized for high-channel-count applications. NI SCC provides portable, flexible signal conditioning options on a per-channel basis. Visit ni.com/sigcon for resources on available NI signal conditioning.

Ordering Information

For a complete list of accessories, visit the product page on ni.com.

Software Recommendations

LabVIEW Professional Development System for Windows

- Advanced software tools for large project development

SignalExpress for Windows

- Quickly configure projects without programming

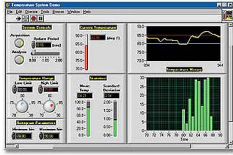

- Automatic code generation using DAQ Assistant and Instrument I/O Assistant
- Tight integration with a wide range of hardware
- Advanced measurement analysis and digital signal processing
- Open connectivity with DLLs, ActiveX, and .NET objects
- Capability to build DLLs, executables, and MSI installers



- Control over 400 PC-based and stand-alone instruments
- Log data from more than 250 data acquisition devices
- Perform basic signal processing, analysis, and file I/O
- Scale your application with automatic LabVIEW code generation
- Create custom reports or easily export data to LabVIEW, DIAdem or Microsoft Excel

NI LabWindows™/CVI for Windows



- Real-time advanced 2D graphs and charts
- Complete hardware compatibility with IVI, VISA, DAQ, GPIB, and serial
- Analysis tools for array manipulation, signal processing statistics, and curve fitting
- Simplified cross-platform communication with network variables
- Measurement Studio .NET tools (included in LabWindows/CVI Full only)
- The mark LabWindows is used under a license from Microsoft Corporation.

NI Measurement Studio Professional Edition

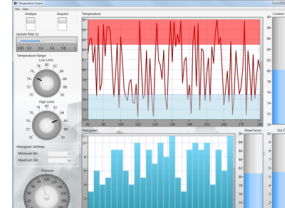

- Customizable graphs and charts for WPF, Windows Forms, and ASP.NET Web Forms UI design
- Analysis libraries for array operations, signal generation, windowing, filters, signal processing
- Hardware integration support with native .NET data acquisition and instrument control libraries
- Automatic code generation for all NI-DAQmx data acquisition hardware
- Intelligent and efficient data-logging libraries for streaming measurement data to disk
- Support for Microsoft Visual Studio .NET 2012/2010/2008

[Back to Top](#)

Support and Services

System Assurance Programs

NI system assurance programs are designed to make it even easier for you to own an NI system. These programs include configuration and deployment services for your NI PXI, CompactRIO, or Compact FieldPoint system. The NI Basic System Assurance Program provides a simple integration test and ensures that your system is delivered completely assembled in one box. When you configure your system with the NI Standard System Assurance Program, you can select from available NI system driver sets and application development environments to create customized, reorderable software configurations. Your system arrives fully assembled and tested in one box with your software preinstalled. When you order your system with the standard program, you also receive system-specific documentation including a bill of materials, an integration test report, a recommended maintenance plan, and frequently asked question documents. Finally, the standard program reduces the total cost of owning an NI system by providing three years of warranty coverage and calibration service. Use the online product advisors at ni.com/advisor to find a system assurance program to meet your needs.

Calibration

NI measurement hardware is calibrated to ensure measurement accuracy and verify that the device meets its published specifications. To ensure the ongoing accuracy of your measurement hardware, NI offers basic or detailed recalibration service that provides ongoing ISO 9001 audit compliance and confidence in your measurements. To learn more about NI calibration services or to locate a qualified service center near you, contact your local sales office or visit ni.com/calibration.

Technical Support

Get answers to your technical questions using the following National Instruments resources.

- **Support** - Visit ni.com/support to access the NI KnowledgeBase, example programs, and tutorials or to contact our applications engineers who are located in NI sales offices around the world and speak the local language.
- **Discussion Forums** - Visit forums.ni.com for a diverse set of discussion boards on topics you care about.
- **Online Community** - Visit community.ni.com to find, contribute, or collaborate on customer-contributed technical content with users like you.

Repair

While you may never need your hardware repaired, NI understands that unexpected events may lead to necessary repairs. NI offers repair services performed by highly trained technicians who quickly return your device with the guarantee that it will perform to factory specifications. For more information, visit ni.com/repair.

Training and Certifications

The NI training and certification program delivers the fastest, most certain route to increased proficiency and productivity using NI software and hardware. Training builds the skills to more efficiently develop robust, maintainable applications, while certification validates your knowledge and ability.

- **Classroom training in cities worldwide** - the most comprehensive hands-on training taught by engineers.
- **On-site training at your facility** - an excellent option to train multiple employees at the same time.
- **Online instructor-led training** - lower-cost, remote training if classroom or on-site courses are not possible.
- **Course kits** - lowest-cost, self-paced training that you can use as reference guides.
- **Training memberships** and training credits - to buy now and schedule training later.

Visit ni.com/training for more information.

Extended Warranty

NI offers options for extending the standard product warranty to meet the life-cycle requirements of your project. In addition, because NI understands that your requirements may change, the extended warranty is flexible in length and easily renewed. For more information, visit ni.com/warranty.

OEM

NI offers design-in consulting and product integration assistance if you need NI products for OEM applications. For information about special pricing and services for OEM customers, visit ni.com/oem.

Alliance

Our Professional Services Team is comprised of NI applications engineers, NI Consulting Services, and a worldwide National Instruments Alliance Partner program of more than 700 independent consultants and integrators. Services range from start-up assistance to turnkey system integration. Visit ni.com/alliance.

[Back to Top](#)

Detailed Specifications

Specifications listed below are typical at 25 °C unless otherwise noted. Refer to the *M Series User Manual* for more information about NI 628x devices.

Analog Input

Number of channels

NI 6280/6281	8 differential or 16 single ended
NI 6284/6289	16 differential or 32 single ended

ADC resolution	18 bits
----------------	---------

DNL	No missing codes guaranteed
-----	-----------------------------

INL	Refer to the <i>AI Absolute Accuracy Tables</i>
-----	---

Sampling rate

Maximum	625 kS/s single channel, 500 kS/s multi-channel (aggregate)
Minimum	No minimum

Timing accuracy	50 ppm of sample rate
-----------------	-----------------------

Timing resolution	50 ns
-------------------	-------

Input coupling	DC
----------------	----

Input range	± 10 V, ± 5 V, ± 2 V, ± 1 V, ± 0.5 V, ± 0.2 V, ± 0.1 V
-------------	--

Maximum working voltage for analog inputs (signal + common mode)	± 11 V of AI GND
--	----------------------

CMRR (DC to 60 Hz)	110 dB
--------------------	--------

Input impedance	
-----------------	--

Device on	
-----------	--

AI+ to AI GND	>10 G Ω in parallel with 100 pF
AI- to AI GND	>10 G Ω in parallel with 100 pF

Device off	
------------	--

AI+ to AI GND	820 Ω
AI- to AI GND	820 Ω

Input bias current	± 100 pA
--------------------	--------------

Crosstalk (at 100 kHz)	
------------------------	--

Adjacent channels	-75 dB
Non-adjacent channels	-95 dB

Small signal bandwidth (-3 dB)	750 kHz filter off, 40 kHz filter on
--------------------------------	---

Input FIFO size	2,047 samples
-----------------	---------------

Scan list memory	4,095 entries
------------------	---------------

Data transfers	
----------------	--

PCI/PXI devices	DMA (scatter-gather), interrupts, programmed I/O
USB devices	USB Signal Stream, programmed I/O

Overvoltage protection (AI <0..31>, AI SENSE, AI SENSE 2)

Device on	±25 V for up to eight AI pins
Device off	±15 V for up to eight AI pins
Input current during overvoltage condition	±20 mA max/AI pin

Settling Time for Multichannel Measurements

Range	Filter Off		Filter On
	±15 ppm of Step (±4 LSB for Full Scale Step)	±4 ppm of Step (±1 LSB for Full Scale Step)	±4 ppm of Step (±1 LSB for Full Scale Step)
±10 V, ±5 V	2 μs	8 μs	50 μs
±2 V, ±1 V, ±0.5 V	2.5 μs	8 μs	50 μs
±0.2 V, ±0.1 V	3 μs	8 μs	50 μs

Typical Performance Graphs

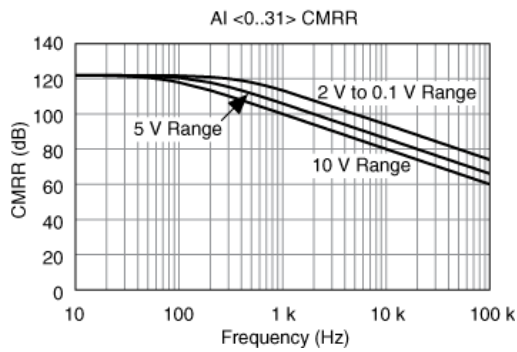
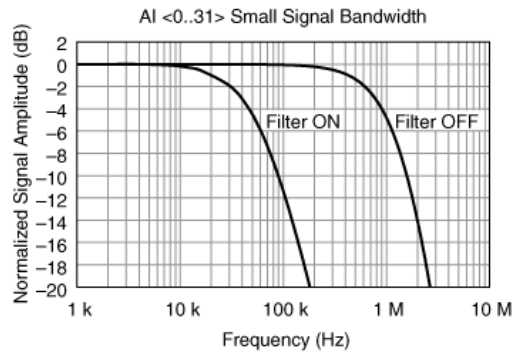
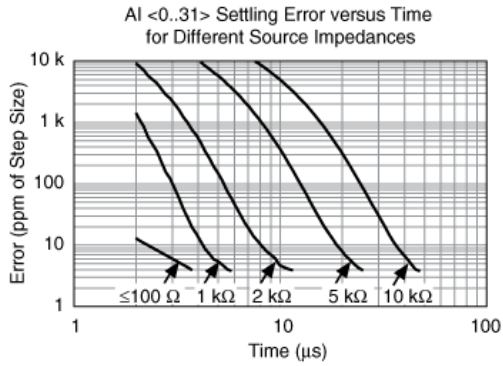

Analog Triggers

Number of triggers	1
Source	
NI 6280/6281	AI <0..15>, APFI 0
NI 6284/6289	AI <0..31>, APFI <0..1>
Functions	Start Trigger, Reference Trigger, Pause Trigger, Sample Clock, Convert Clock, Sample Clock Timebase
Source level	
AI <0..31>	±Full scale
APFI <0..1>	±10 V
Resolution	10 bits, 1 in 1024
Modes	Analog edge triggering, analog edge triggering with hysteresis, and analog window triggering
Bandwidth (-3 dB)	

AI <0..31>	700 kHz filter off, 40 kHz filter on
APFI <0..1>	5 MHz
Accuracy	±1%
APFI <0..1> characteristics	
Input impedance	10 kΩ
Coupling	DC
Protection	
Power on	±30 V
Power off	±15 V

Analog Output

Number of channels	
NI 6280/6284	0
NI 6281	2
NI 6289	4
DAC resolution	16 bits
DNL	±1 LSB
Monotonicity	16 bit guaranteed
Accuracy	Refer to the <i>AO Absolute Accuracy Table</i>
Maximum update rate	
1 channel	2.86 MS/s
2 channels	2.00 MS/s
3 channels	1.54 MS/s
4 channels	1.25 MS/s
Timing accuracy	50 ppm of sample rate
Timing resolution	50 ns
Output range	
Offset	Offset ± reference, includes ±10 V, ±5 V, ±2 V, and ±1 V calibrated ranges
Reference	0 V, 5 V, APFI <0..1>, AO <0..3> ¹
Maximum output level	10 V, 5 V, 2 V, 1 V, APFI <0..1>, AO <0..3> ¹
Output coupling	±11 V
Output impedance	DC
Output current drive	0.2 Ω
Overdrive protection	±5 mA
Overdrive current	±25 V
Power-on state	20 mA
Power-on glitch	±5 mV ²
Output FIFO size	2.3 V peak for 1.2 s
Data transfers	8,191 samples shared among channels used
PCI/PXI devices	DMA (scatter-gather), interrupts, programmed I/O
USB devices	USB Signal Stream, programmed I/O
AO waveform modes:	
<ul style="list-style-type: none"> ▪ Non-periodic waveform ▪ Periodic waveform regeneration mode from onboard FIFO ▪ Periodic waveform regeneration from host buffer including dynamic update 	
Settling time, full scale step 15 ppm (1 LSB)	3 μs
Slew rate	20 V/μs

Glitch energy at midscale transition, ±10 V range

Magnitude	15 mV
Duration	0.5 μs

¹ An AO channel cannot be a reference or offset to itself.

² For all USB-6281/6289 Screw Terminal devices, when powered on, the analog output signal is not defined until after USB configuration is complete.

External Reference

APFI <0..1> characteristics

Input impedance	10 kΩ
Coupling	DC
Protection	
Power on	±30 V
Power off	±15 V
Range	±11 V

AO <0..3> Analog Output External Reference Bandwidth

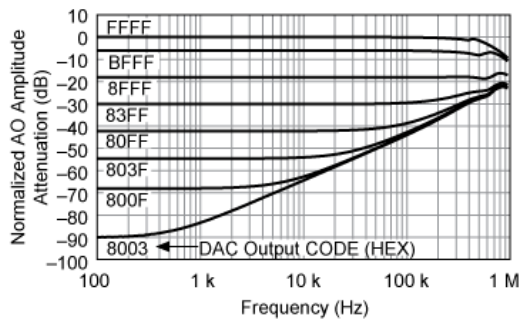

Calibration (AI and AO)

Recommended warm-up time

PCI/PXI devices	15 minutes
USB devices	30 minutes
Calibration interval	2 years

AI Absolute Accuracy Table (Filter On)

Nominal Range		Residual Gain Error (ppm of Reading)	Gain Tempco (ppm/°C)	Reference Tempco	Residual Offset Error (ppm of Range)	Offset Tempco (ppm of Range/°C)	INL Error (ppm of Range)	Random Noise, σ (μVrms)	Absolute Accuracy at Full Scale ¹ (μV)	Sensitivity ² (μV)
Positive Full Scale	Negative Full Scale									
10	-10	40	17	1	8	11	10	60	980	24
5	-5	45	17	1	8	11	10	30	510	12
2	-2	45	17	1	8	13	10	12	210	4.8
1	-1	55	17	1	15	15	10	7	120	2.8
0.5	-0.5	55	17	1	30	20	10	4	70	1.6
0.2	-0.2	75	17	1	45	35	10	3	39	1.2
0.1	-0.1	120	17	1	60	60	10	2	28	0.8

Accuracies listed are valid for up to two years from the device external calibration.

$$\text{AbsoluteAccuracy} = \text{Reading} \cdot (\text{GainError}) + \text{Range} \cdot (\text{OffsetError}) + \text{NoiseUncertainty}$$

$$\text{GainError} = \text{ResidualAIGainError} + \text{GainTempco} \cdot (\text{TempChangeFromLastInternalCal}) + \text{ReferenceTempco} \cdot (\text{TempChangeFromLastExternalCal})$$

$$\text{OffsetError} = \text{ResidualAIOffsetError} + \text{OffsetTempco} \cdot (\text{TempChangeFromLastInternalCal}) + \text{INL_Error}$$

$$\text{NoiseUncertainty} = \frac{\text{RandomNoise} \cdot 3}{\sqrt{100}} \quad \text{For a coverage factor of } 3 \sigma \text{ and averaging 100 points.}$$

¹ Absolute accuracy at full scale on the analog input channels is determined using the following assumptions:

TempChangeFromLastExternalCal = 10 °C
 TempChangeFromLastInternalCal = 1 °C
 number_of_readings = 100
 CoverageFactor = 3 σ

For example, on the 10 V range, the absolute accuracy at full scale is as follows:
 GainError = 40 ppm + 17 ppm · 1 + 1 ppm · 10 GainError = 67 ppm
 OffsetError = 8 ppm + 11 ppm · 1 + 10 ppm OffsetError = 29 ppm

$$\text{NoiseUncertainty} = \frac{60 \mu\text{V} \cdot 3}{\sqrt{100}} \quad \text{NoiseUncertainty} = 18 \mu\text{V}$$

AbsoluteAccuracy = 10 V · (GainError) + 10 V · (OffsetError) + NoiseUncertainty AbsoluteAccuracy = 980 μV

² Sensitivity is the smallest voltage change that can be detected. It is a function of noise.

AI Absolute Accuracy Table (Filter Off)

Nominal Range		Residual Gain Error (ppm of Reading)	Gain Tempco (ppm/°C)	Reference Tempco	Residual Offset Error (ppm of Range)	Offset Tempco (ppm of Range/°C)	INL Error (ppm of Range)	Random Noise, σ (μVrms)	Absolute Accuracy at Full Scale ¹ (μV)	Sensitivity ² (μV)
Positive Full Scale	Negative Full Scale									
10	-10	45	17	1	10	11	10	70	1050	28.0
5	-5	50	17	1	10	11	10	35	550	14.0
2	-2	50	17	1	10	13	10	15	230	6.0
1	-1	60	17	1	17	15	10	12	130	4.8
0.5	-0.5	60	17	1	32	20	10	10	80	4.0
0.2	-0.2	80	17	1	47	35	10	9	43	3.6
0.1	-0.1	120	17	1	62	60	10	9	31	3.6

Accuracies listed are valid for up to two years from the device external calibration.
 AbsoluteAccuracy = Reading · (GainError) + Range · (OffsetError) + NoiseUncertainty
 GainError = ResidualAIGainError + GainTempco · (TempChangeFromLastInternalCal) + ReferenceTempco · (TempChangeFromLastExternalCal)
 OffsetError = ResidualAIOffsetError + OffsetTempco · (TempChangeFromLastInternalCal) + INL_Error

$$\text{NoiseUncertainty} = \frac{\text{RandomNoise} \cdot 3}{\sqrt{100}} \quad \text{For a coverage factor of } 3 \sigma \text{ and averaging } 100 \text{ points.}$$

¹ Absolute accuracy at full scale on the analog input channels is determined using the following assumptions:
 TempChangeFromLastExternalCal = 10 °C
 TempChangeFromLastInternalCal = 1 °C
 number_of_readings = 100
 CoverageFactor = 3 σ

For example, on the 10 V range, the absolute accuracy at full scale is as follows:
 GainError = 45 ppm + 17 ppm · 1 + 1 ppm · 10 GainError = 72 ppm
 OffsetError = 10 ppm + 11 ppm · 1 + 10 ppm OffsetError = 31 ppm

$$\text{NoiseUncertainty} = \frac{70 \mu\text{V} \cdot 3}{\sqrt{100}} \quad \text{NoiseUncertainty} = 21 \mu\text{V}$$

AbsoluteAccuracy = 10 V · (GainError) + 10 V · (OffsetError) + NoiseUncertainty AbsoluteAccuracy = 1050 μV

² Sensitivity is the smallest voltage change that can be detected. It is a function of noise.

AO Absolute Accuracy Table

Nominal Range		Residual Gain Error (ppm of Reading)	Gain Tempco (ppm/°C)	Reference Tempco	Residual Offset Error (ppm of Range)	Offset Tempco (ppm of Range/°C)	INL Error (ppm of Range)	Absolute Accuracy at Full Scale ¹ (μV)
Positive Full Scale	Negative Full Scale							
10	-10	55	15	1	30	12	32	1540
5	-5	60	15	1	30	17	32	820
2	-2	65	25	1	40	30	32	404
1	-1	85	25	1	57	50	32	259

¹ Absolute Accuracy at full scale numbers is valid immediately following internal calibration and assumes the device is operating within 10 °C of the last external calibration.

Accuracies listed are valid for up to two years from the device external calibration.

$$\text{AbsoluteAccuracy} = \text{OutputValue} \cdot (\text{GainError}) + \text{Range} \cdot (\text{OffsetError})$$

$$\text{GainError} = \text{ResidualGainError} + \text{GainTempco} \cdot (\text{TempChangeFromLastInternalCal}) + \text{ReferenceTempco} \cdot (\text{TempChangeFromLastExternalCal})$$

$$\text{OffsetError} = \text{ResidualOffsetError} + \text{AOffsetTempco} \cdot (\text{TempChangeFromLastInternalCal}) + \text{INL_Error}$$

Digital I/O/PFI

Static Characteristics

Number of channels

NI 6280/6281	24 total 8 (P0.<0..7>) 16 (PFI <0..7>/P1, PFI <8..15>/P2)
NI 6284/6289	48 total 32 (P0.<0..31>) 16 (PFI <0..7>/P1, PFI <8..15>/P2)
I/O type	5 V TTL/CMOS compatible
Ground reference	D GND
Direction control	Each terminal individually programmable as input or output
Pull-down resistor	50 kΩ typical, 20 kΩ minimum
Input voltage protection ³	±20 V on up to two pins

³ Stresses beyond those listed under *Input voltage protection* may cause permanent damage to the device.

Waveform Characteristics (Port 0 Only)

Terminals used

NI 6280/6281	Port 0 (P0.<0..7>)
NI 6284/6289	Port 0 (P0.<0..31>)

Port/sample size

NI 6280/6281	Up to 8 bits
NI 6284/6289	Up to 32 bits

Waveform generation (DO) FIFO

2,047 samples

Waveform acquisition (DI) FIFO

2,047 samples

DI Sample Clock frequency

PCI/PXI devices	0 to 10 MHz ⁴
USB devices	0 to 1 MHz system dependent ⁴

DO Sample Clock frequency

PCI/PXI devices	
Regenerate from FIFO	0 to 10 MHz
Streaming from memory	0 to 10 MHz system dependent ⁴
USB devices	
Regenerate from FIFO	0 to 10 MHz
Streaming from memory	0 to 1 MHz system dependent ⁴

Data transfers

PCI/PXI devices	DMA (scatter-gather), interrupts, programmed I/O
USB devices	USB Signal Stream, programmed I/O

DO or DI Sample Clock source⁵

Any PFI, RTSI, AI Sample or Convert Clock, AO Sample Clock, Ctr *n* Internal Output, and many other signals

⁴ Performance can be dependent on bus latency and volume of bus activity.

⁵ The digital subsystem does not have its own dedicated internal timing engine. Therefore, a sample clock must be provided from another subsystem on the device or an external source.

PFI/Port 1/Port 2 Functionality

Functionality

Static digital input, static digital output, timing input, timing output

Timing output sources

Many AI, AO, counter, DI, DO timing signals

Debounce filter settings

125 ns, 6.425 μ s, 2.56 ms, disable; high and low transitions; selectable per input

Recommended Operation Conditions		
Level	Min	Max
Input high voltage (V_{IH})	2.2 V	5.25 V
Input low voltage (V_{IL})	0 V	0.8 V
Output high current (I_{OH})		
P0.<0..31>	—	-24 mA
PFI <0..15>/P1/P2	—	-16 mA
Output low current (I_{OL})		
P0.<0..31>	—	24 mA
PFI <0..15>/P1/P2	—	16 mA

Electrical Characteristics		
Level	Min	Max
Positive-going threshold (V_{T+})	—	2.2 V
Negative-going threshold (V_{T-})	0.8 V	—
Delta VT hysteresis ($V_{T+} - V_{T-}$)	0.2 V	—
I_{IL} input low current ($V_{in} = 0$ V)	—	-10 μ A
I_{IH} input high current ($V_{in} = 5$ V)	—	250 μ A

Digital I/O Characteristics

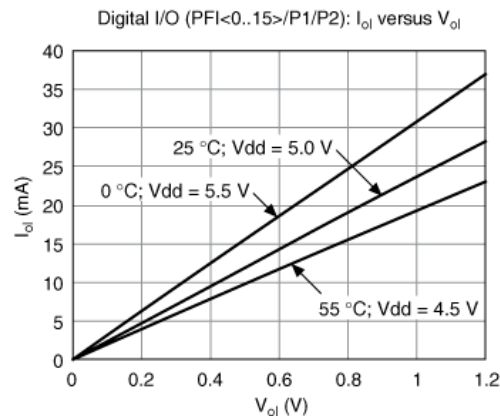
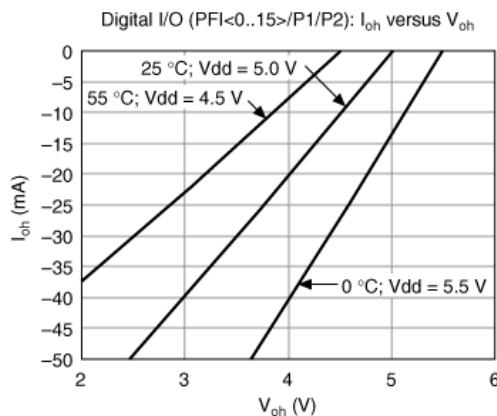
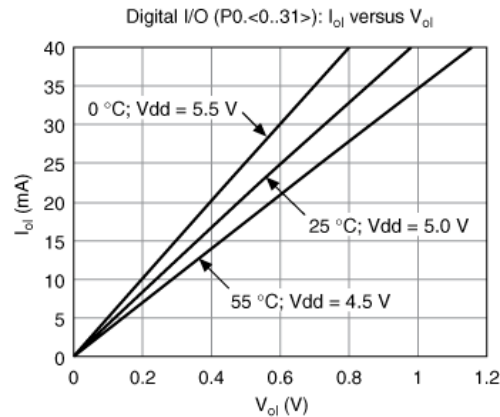
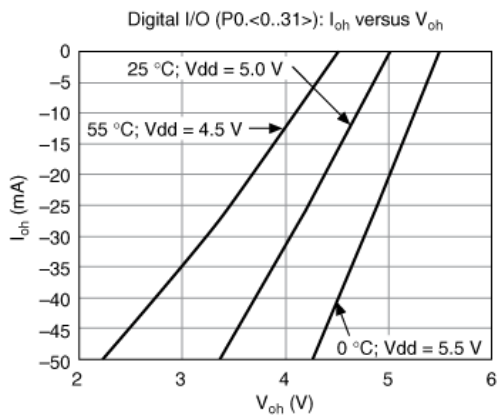

Number of counter/timers	2
Resolution	32 bits
Counter measurements	Edge counting, pulse, semi-period, period, two-edge separation
Position measurements	X1, X2, X4 quadrature encoding with Channel Z reloading; two-pulse encoding
Output applications	Pulse, pulse train with dynamic updates, frequency division, equivalent time sampling
Internal base clocks	80 MHz, 20 MHz, 0.1 MHz
External base clock frequency	0 MHz to 20 MHz
Base clock accuracy	50 ppm
Inputs	Gate, Source, HW_Arm, Aux, A, B, Z, Up_Down
Routing options for inputs	Any PFI, RTSI, PXI_TRIG, PXI_STAR, analog trigger, many internal signals
FIFO	2 samples
Data transfers	
PCI/PCIe/PXI/PXLe devices	Dedicated scatter-gather DMA controller for each counter/timer; interrupts, programmed I/O
USB devices	USB Signal Stream, programmed I/O

Frequency Generator

Number of channels	1
Base clocks	10 MHz, 100 kHz
Divisors	1 to 16
Base clock accuracy	50 ppm

Output can be available on any PFI or RTSI terminal.

Phase-Locked Loop (PLL) (PCI/PXI Devices Only)

Number of PLLs	1
Reference signal	PXI_STAR, PXI_CLK10, RTSI <0..7>
Output of PLL	80 MHz Timebase; other signals derived from 80 MHz Timebase including 20 MHz and 100 kHz Timebases

External Digital Triggers

Source	Any PFI, RTSI, PXI_TRIG, PXI_STAR
Polarity	Software-selectable for most signals
Analog input function	Start Trigger, Reference Trigger, Pause Trigger, Sample Clock, Convert Clock, Sample Clock Timebase
Analog output function	Start Trigger, Pause Trigger, Sample Clock, Sample Clock Timebase
Counter/timer functions	Gate, Source, HW_Arm, Aux, A, B, Z, Up_Down
Digital waveform generation (DO) function	Sample Clock
Digital waveform acquisition (DI) function	Sample Clock

Device-To-Device Trigger Bus

PCI devices	RTSI <0..7> ⁶
PXI devices	PXI_TRIG <0..7>, PXI_STAR
USB devices	None
Output selections	10 MHz Clock; frequency generator output; many internal signals
Debounce filter settings	125 ns, 6.425 μ s, 2.56 ms, disable; high and low transitions; selectable per input

⁶ In other sections of this document, *RTSI* refers to RTSI <0..7> for PCI devices or PXI_TRIG <0..7> for PXI devices.

Bus Interface

PCI/PXI devices	3.3 V or 5 V signal environment
-----------------	---------------------------------

USB devices	USB 2.0 Hi-Speed or full-speed ^{7,8}
DMA channels (PCI/PXI devices)	6, analog input, analog output, digital input, digital output, counter/timer 0, counter/timer 1
USB Signal Stream (USB devices)	4, can be used for analog input, analog output, digital input, digital output, counter/timer 0, counter/timer 1

All PXI-628x devices support one of the following features:

- May be installed in PXI Express hybrid slots
- Or, may be used to control SCXI in PXI/SCXI combo chassis

Table 1. PXI/SCXI Combo and PXI Express Chassis Compatibility

M Series Device	M Series Part Number	SCXI Control in PXI/SCXI Combo Chassis	PXI Express Hybrid Slot Compatible
PXI-6280	191501C-04	No	Yes
PXI-6281	191501C-03	No	Yes
PXI-6284	191501C-02	No	Yes
PXI-6289	191501C-01	No	Yes
	191501C-11	Yes	No
Earlier versions of PXI-628x	191501A-0x	Yes	No
	191501B-0x		

⁷ If you are using a USB M Series device in full-speed mode, device performance will be lower and you will not be able to achieve maximum sampling/update rates.

⁸ Operating on a full-speed bus may result in lower performance.

Power Requirements

PCI/PXI devices

Current draw from bus during no-load condition⁹

+5 V	0.03 A
+3.3 V	0.78 A
+12 V	0.40 A
-12 V	0.06 A

PCI/PXI devices

Current draw from bus during AI and AO overvoltage condition⁹

+5 V	0.03 A
+3.3 V	1.26 A
+12 V	0.43 A
-12 V	0.06 A

 **Caution** USB-628x devices *must* be powered with NI offered AC adapter or a National Electric Code (NEC) Class I device and has appropriate safety certification marks for country of use.

USB devices

Power supply requirements	11 to 30 VDC, 20 W, locking or non-locking power jack with 0.080 in. diameter center pin, 5/16-32 thread for locking collars
Power supply fuse	2 A, 250 V

⁹ Does not include P0/PFI/P1/P2 and +5 V terminals.

Power Limits

 **Caution** Exceeding the power limits may cause unpredictable behavior by the device and/or PC/chassis.

PCI devices

+5 V terminal (connector 0)	1 A max ¹⁰
+5 V terminal (connector 1)	1 A max ¹⁰

PXI devices

+5 V terminal (connector 0)	1 A max ¹⁰
-----------------------------	-----------------------

+5 V terminal (connector 1)	1 A max ¹⁰
P0/PFI/P1/P2 and +5 V terminals combined	2 A max
USB devices	
+5 V terminal	1 A max ¹¹
P0/PFI/P1/P2 and +5 V terminals combined	2 A max

¹⁰ Older revisions have a self-resetting fuse that opens when current exceeds this specification. Newer revisions have a traditional fuse that opens when current exceeds this specification. This fuse is not customer-replaceable; if the fuse permanently opens, return the device to NI for repair.

¹¹ Has a self-resetting fuse that opens when current exceeds this specification.

Physical Requirements

Printed circuit board dimensions

NI PCI-6280/6281/6284/6289	10.6 cm x 15.5 cm (4.2 in. x 6.1 in.)
NI PXI-6280/6281/6284/6289	Standard 3U PXI

Enclosure dimensions (includes connectors)

NI USB-6281/6289 Mass Termination	18.8 x 17.09 x 4.45 cm (7.4 x 6.73 x 1.75 in.)
NI USB-6281/6289 Screw Terminal	26.67 x 17.09 x 4.45 cm (10.5 x 6.73 x 1.75 in.)
NI USB-6258/6289 OEM	Refer to the <i>NI USB-622x/625x/628x OEM User Guide</i>

Weight

NI PCI-6280	151 g (5.3 oz)
NI PCI-6281	158 g (5.6 oz)
NI PCI-6284	159 g (5.6 oz)
NI PCI-6289	167 g (5.9 oz)
NI PXI-6280	218 g (7.7 oz)
NI PXI-6281	225 g (7.9 oz)
NI PXI-6284	229 g (8.1 oz)
NI PXI-6289	237 g (8.4 oz)
NI USB-6281 Mass Termination	1.04 kg (2 lb 4.5 oz)
NI USB-6289 Mass Termination	1.06 kg (2 lb 5.5 oz)
NI USB-6281 OEM	261 g (9.2 oz)
NI USB-6289 OEM	274 g (9.6 oz)
NI USB-6281 Screw Terminal	1.46 kg (3 lb 3.4 oz)
NI USB-6289 Screw Terminal	1.52 kg (3 lb 5.5 oz)

I/O connector

NI PCI/PXI-6280/6281	1 68-pin VHDCI
NI PCI/PXI-6284/6289	2 68-pin VHDCI
NI USB-6281 Mass Termination	1 68-pin SCSI
NI USB-6289 Mass Termination	2 68-pin SCSI
NI USB-6281 OEM	1 34-pin IDC, 1 50-pin IDC
NI USB-6289 OEM	2 34-pin IDC, 2 50-pin IDC
NI USB-6281 Screw Terminal	64 screw terminals
NI USB-6289 Screw Terminal	128 screw terminals
USB-6281/6289 Screw Terminal wiring	16-28 AWG

Maximum Working Voltage¹²

NI 6280/6281/6284/6289 channel-to-earth	11 V, Measurement Category I
---	------------------------------



Caution Do not use for measurements within Categories II, III, or IV.

¹² *Maximum working voltage* refers to the signal voltage plus the common-mode voltage.

Environmental

Operating temperature

PCI/PXI devices	0 to 55 °C
USB devices	0 to 45 °C
Storage temperature	-20 to 70 °C
Humidity	10 to 90% RH, noncondensing
Maximum altitude	2,000 m
Pollution Degree (indoor use only)	2

Shock and Vibration (PXI Devices Only)

Operational shock	30 g peak, half-sine, 11 ms pulse (Tested in accordance with IEC-60068-2-27. Test profile developed in accordance with MIL-PRF-28800F.)
Random vibration	
Operating	5 to 500 Hz, 0.3 g _{rms}
Nonoperating	5 to 500 Hz, 2.4 g _{rms} (Tested in accordance with IEC-60068-2-64. Nonoperating test profile exceeds the requirements of MIL-PRF-28800F, Class 3.)

Safety

This product is designed to meet the requirements of the following standards of safety for electrical equipment for measurement, control, and laboratory use:

- IEC 61010-1, EN 61010-1
- UL 61010-1, CSA 61010-1



Note For UL and other safety certifications, refer to the product label or the *Online Product Certification* section

Electromagnetic Compatibility

This product meets the requirements of the following EMC standards for electrical equipment for measurement, control, and laboratory use:

- EN 61326 (IEC 61326): Class A emissions; Basic immunity
- EN 55011 (CISPR 11): Group 1, Class A emissions
- AS/NZS CISPR 11: Group 1, Class A emissions
- FCC 47 CFR Part 15B: Class A emissions
- ICES-001: Class A emissions



Note For the standards applied to assess the EMC of this product, refer to the Online Product Certification section.



Note For EMC compliance, operate this product according to the documentation.



Note For EMC compliance, operate this device with shielded cables.

CE Compliance

This product meets the essential requirements of applicable European Directives as follows:

- 2006/95/EC; Low-Voltage Directive (safety)
- 2004/108/EC; Electromagnetic Compatibility Directive (EMC)

Online Product Certification

Refer to the product Declaration of Conformity (DoC) for additional regulatory compliance information. To obtain product certifications and the DoC for this product, visit ni.com/certification, search by model number or product line, and click the appropriate link in the Certification column.

Environmental Management

NI is committed to designing and manufacturing products in an environmentally responsible manner. NI recognizes that eliminating certain hazardous substances from our products is beneficial not only to the environment but also to NI customers.

For additional environmental information, refer to the *NI and the Environment* Web page at ni.com/environment. This page contains the environmental regulations and directives with which NI complies, as well as other environmental information not included in this document.

Waste Electrical and Electronic Equipment (WEEE)



EU Customers At the end of their life cycle, all products *must* be sent to a WEEE recycling center. For more information about WEEE recycling centers and National Instruments WEEE initiatives, visit ni.com/environment/weee.htm.

电子信息产品污染控制管理办法（中国 RoHS）



中国客户 National Instruments 符合中国电子信息产品中限制使用某些有害物质指令 (RoHS)。
关于 National Instruments 中国 RoHS 合规性信息, 请登录 ni.com/environment/rohs_china。
(For information about China RoHS compliance, go to ni.com/environment/rohs_china.)

[Back to Top](#)

Pinouts/Front Panel Connections

AI 0	68	34	AI 8
AI GND	67	33	AI 1
AI 9	66	32	AI GND
AI 2	65	31	AI 10
AI GND	64	30	AI 3
AI 11	63	29	AI GND
AI SENSE	62	28	AI 4
AI 12	61	27	AI GND
AI 5	60	26	AI 13
AI GND	59	25	AI 6
AI 14	58	24	AI GND
AI 7	57	23	AI 15
AI GND	56	22	NC
NC	55	21	NC
NC	54	20	APFI 0
D GND	53	19	P0.4
P0.0	52	18	D GND
P0.5	51	17	P0.1
D GND	50	16	P0.6
P0.2	49	15	D GND
P0.7	48	14	+5 V
P0.3	47	13	D GND
PFI 11/P2.3	46	12	D GND
PFI 10/P2.2	45	11	PFI 0/P1.0
D GND	44	10	PFI 1/P1.1
PFI 2/P1.2	43	9	D GND
PFI 3/P1.3	42	8	+5 V
PFI 4/P1.4	41	7	D GND
PFI 13/P2.5	40	6	PFI 5/P1.5
PFI 15/P2.7	39	5	PFI 6/P1.6
PFI 7/P1.7	38	4	D GND
PFI 8/P2.0	37	3	PFI 9/P2.1
D GND	36	2	PFI 12/P2.4
D GND	35	1	PFI 14/P2.6

NC = No Connect

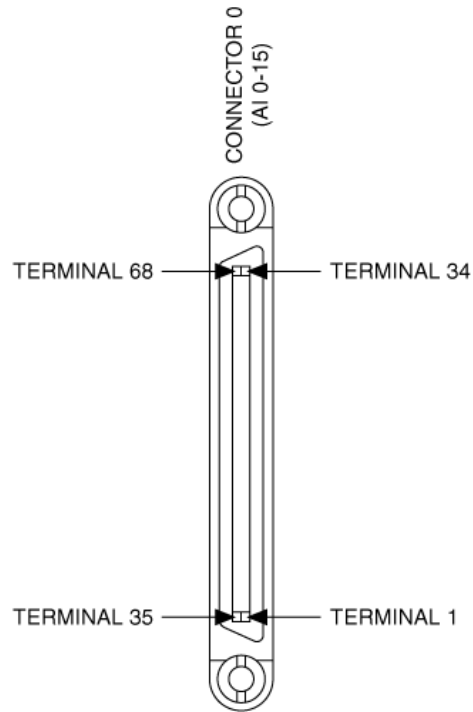

NI PCI/PXI-6280 Pinout

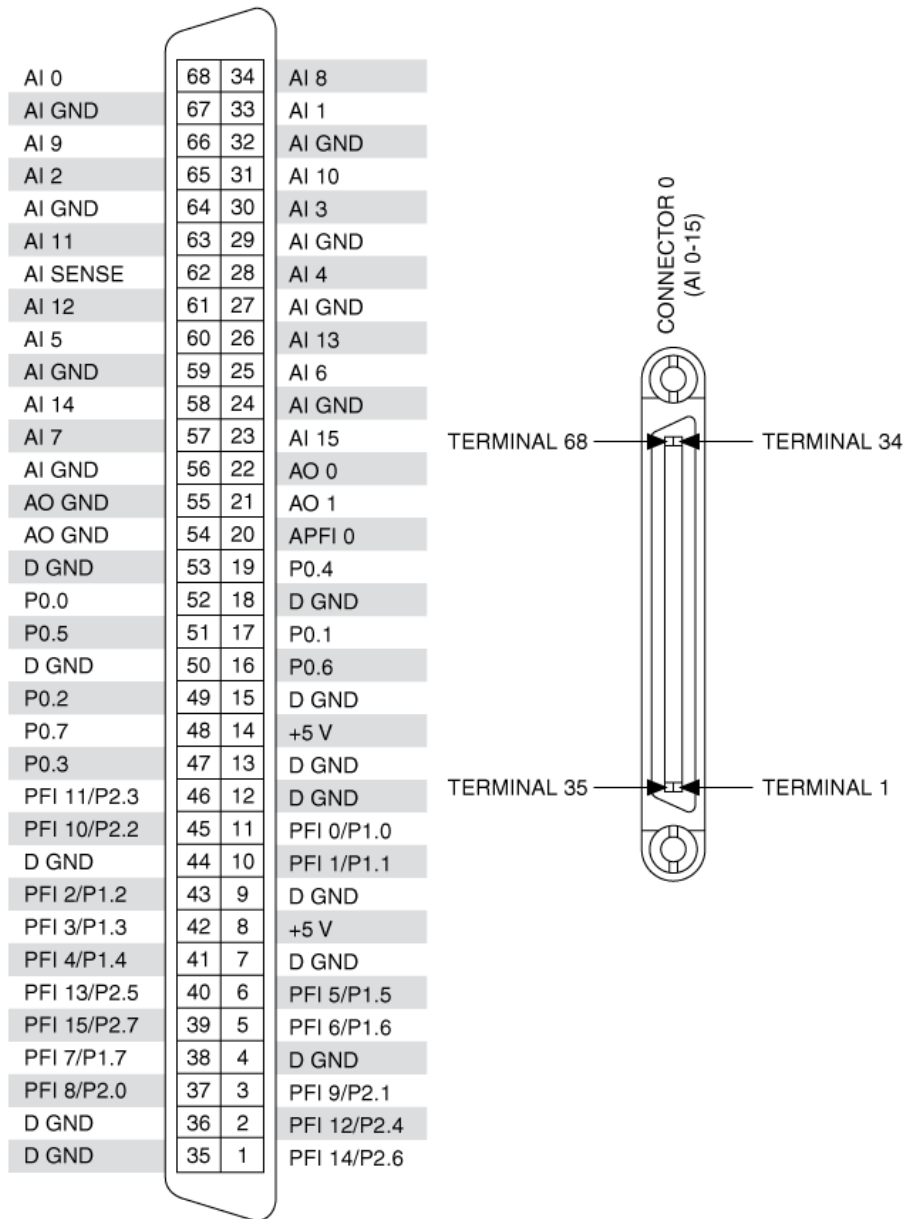

NI PCI/PXI-6281 Pinout

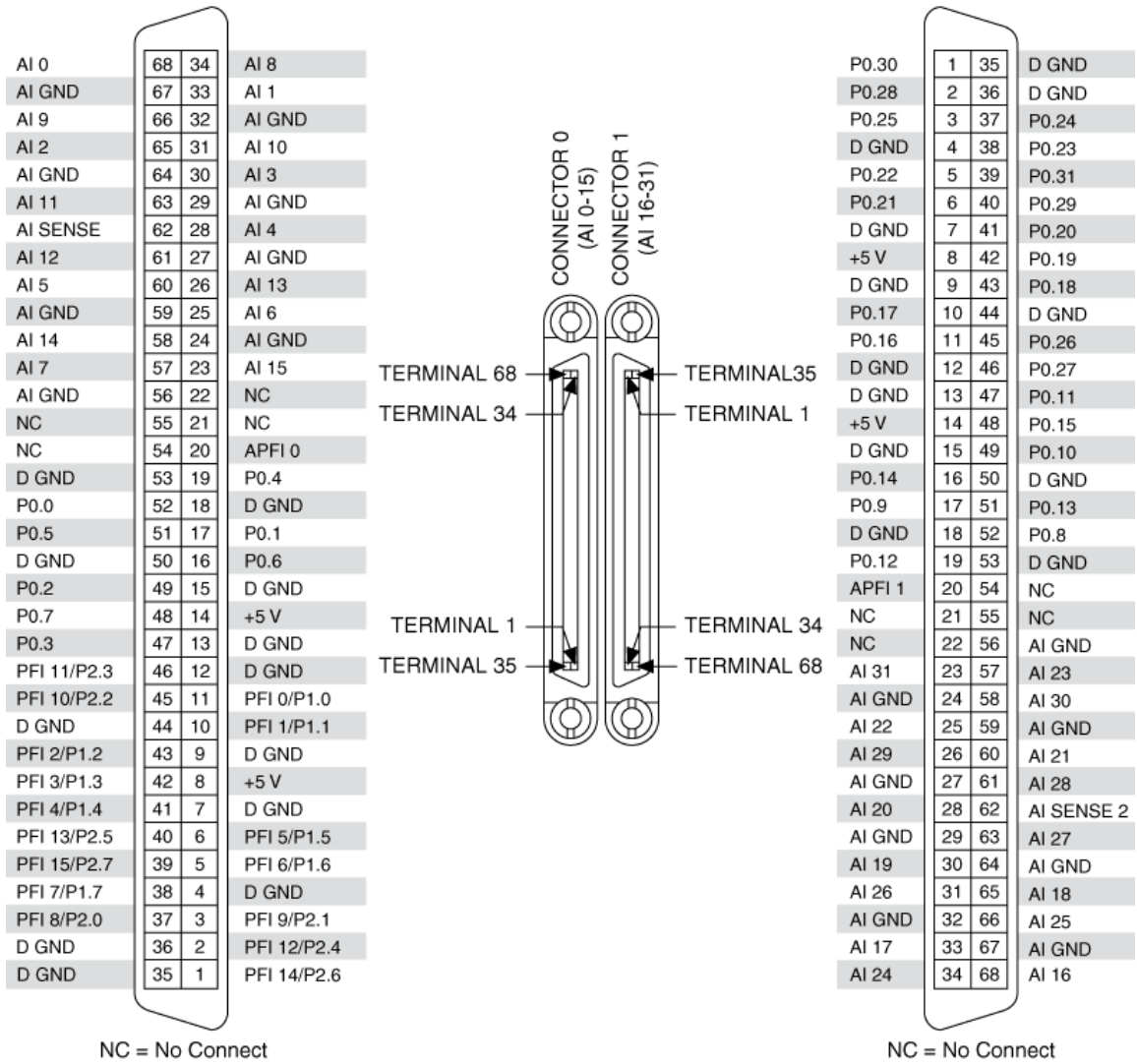

NI PCI/PXI-6284 Pinout

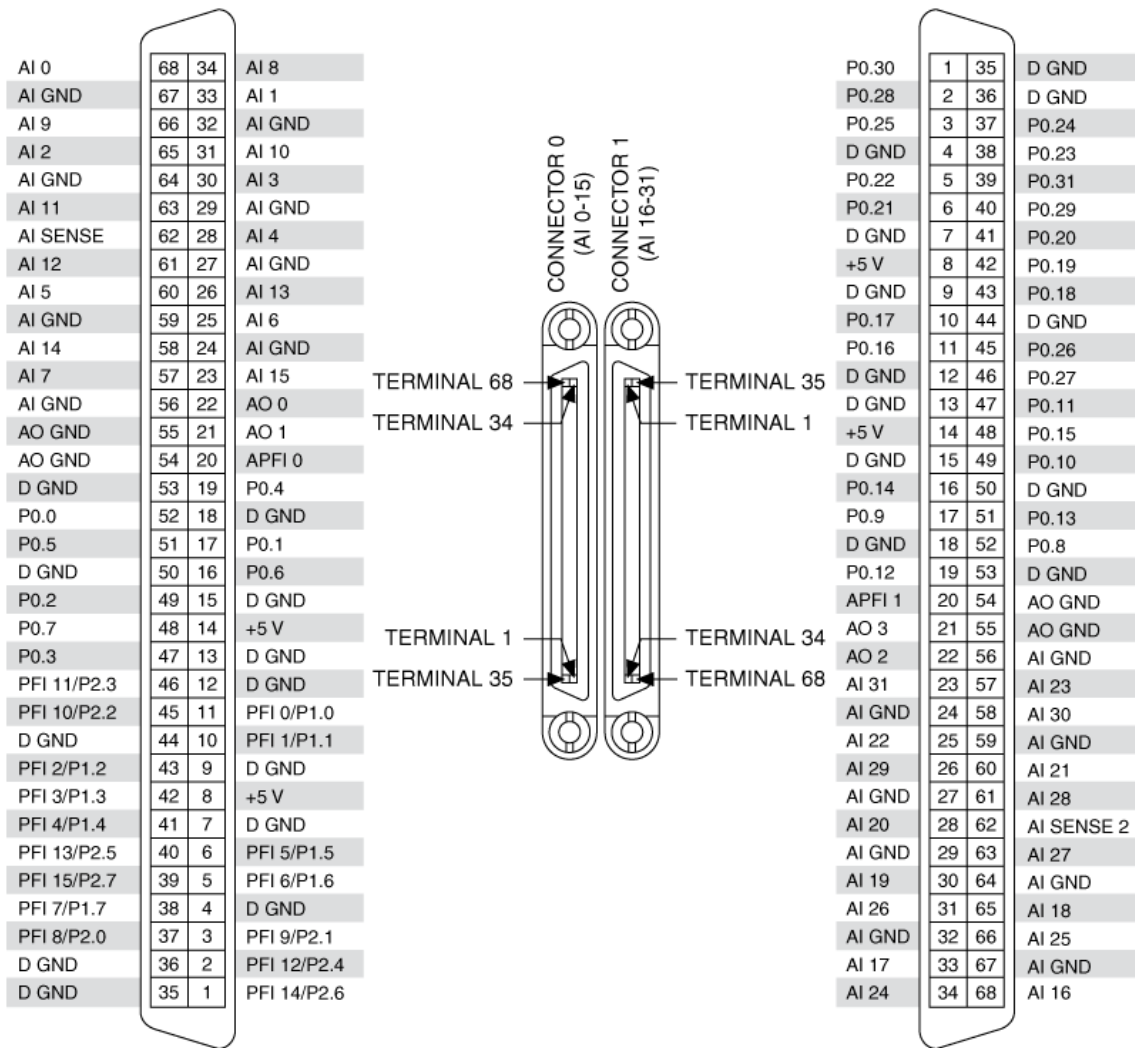

NI PCI/PXI-6289 Pinout

[Back to Top](#)

©2008 National Instruments. All rights reserved. CVI, DIAdem, LabVIEW, Measurement Studio, National Instruments, National Instruments Alliance Partner, NI, ni.com, NI SoftMotion, SCXI, and SignalExpress are trademarks of National Instruments. The mark LabWindows is used under a license from Microsoft Corporation. Windows is a registered trademark of Microsoft Corporation in the United States and other countries. Linux® is the registered trademark of Linus Torvalds in the U.S. and other countries. Other product and company names listed are trademarks or trade names of their respective companies. A National Instruments Alliance Partner is a business entity independent from National Instruments and has no agency, partnership, or joint-venture relationship with National Instruments.

[My Profile](#) | [RSS](#) | [Privacy](#) | [Legal](#) | [Contact NI](#) © 2014 National Instruments Corporation. All rights reserved.